



- Easily Programmed from the Front Panel
- **Software Functions Include:**
  - Password*                      *Display Scaling*
  - Set Point Programming*      *Decimal Point Selection*
- *Screw Terminal Connectors for Easy Installation*
- *Rugged, High-Impact Plastic Case Fits Standard 1/8 DIN Cutout*
- *3.24" (82mm) for Restricted Space Behind Panel*
- *Remote Reset Capability*
- *Input Variety: Quadrature, Switch, TTL, CMOS, NAMUR, PNP, NPN*



Typically used in applications involving speed, the S661 rate counter is capable of counting in four different time modes: hours, seconds, and seconds/thousand (msec). The msec rate mode increases the frequency resolution to .001Hz within the range from 1 to 999.999Hz.

The S661 is compactly designed and features a standard 1/8 DIN case made of PBT-ABS alloy. Screw terminals are standard for easy installation and removal of the meter.

The counter is powered from 120 or 240VAC and has a non-volatile EEPROM to retain all programming and count information when the power source is removed or interrupted. An optional 12VDC (100mA) excitation output module can provide power for external sensors.

Optional field-replaceable signal/dual relay modules enhance the counter from a passive display device to an integral control element for your application. This versatile counter has latching, boundary or timed (0.01 to 599.99 seconds) output modes.

### Installation and Panel Cutout

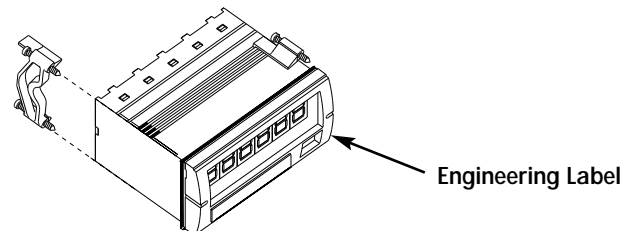
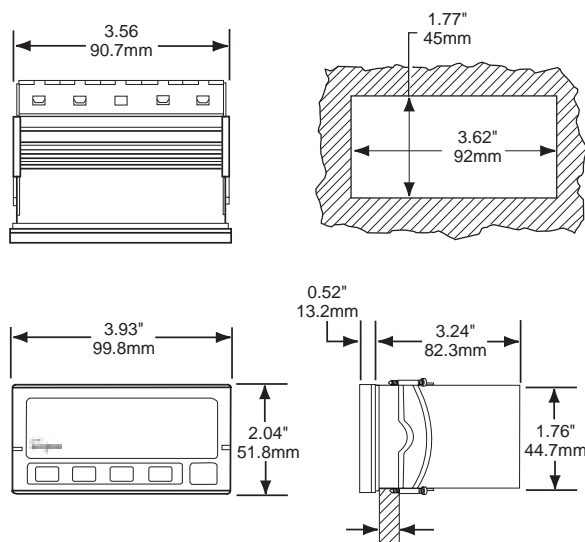

#### Mounting Requirements

The S660 series 1/8 DIN counters require a panel cutout of 1.77" (45mm) high by 3.62" (92mm) wide. To install the counter into a panel cutout, remove the clips from the side of the meter. Slide the meter through your panel cutout, then slide the mounting clips back on the meter. Press evenly to ensure a proper fit.

#### Engineering Label Placement

If replacement of the engineering unit label is required, place the tip of a ball-point pen into the small hole at the base of the engineering label in the bezel. Slide the label up until it pops out. Grasp and remove. Slide the new label half the distance in, then use the ball-point pen to slide it down into place.

## Specifications

### DISPLAY

**Type:** 6-digit, 7-segment, red LED  
**Height:** 0.56" (14.2mm)  
**Decimal Point:** User-programmable  
**Count Direction:** "+" indication implied, "-" indication displayed  
**Display Range:** -99,999 to +999,999  
**Output Indicators:** 1 and 2

### POWER REQUIREMENTS

**AC Voltages:** 120, 240VAC,  $\pm 10\%$   
**Power Consumption:** 3VA

### INPUT RATINGS

**Current Sinking:** 10K $\Omega$  5% Resistor pull-up to (9.0 - 16VDC)  $\pm 10\%$   
**Current Sourcing:** 5.1K $\Omega$  5% Resistor pull-down to common

**Minimum Pulse Width:**  $-5\mu s$   
**Low Pass Filter:**  $<200\text{Hz}$   
**Low Bias:** VLT =  $1.6\text{V} \pm 10\%$   
VUT =  $3.6\text{V} \pm 10\%$   
**High Bias:** VLT =  $5.0\text{V} \pm 10\%$   
VUT =  $7.0\text{V} \pm 10\%$   
**Count Rate:** 30KHz (Pulse Max)  
7.5KHz (Quadrature X4 Max)  
**Maximum Voltage Input**  
**A, B, and User:** 30VDC (Max)

### INPUT

**User Input:** (Display Hold) Display is frozen when the User Input is pulled low.  
**Standard Input:** VLT =  $0.2\text{VDC}$  guaranteed low, VUT = 3.0VDC

**Quadrature Input:** VLT  $\leq 0.9\text{VDC}$   
VUT  $\geq 3.15\text{VDC}$

### ENVIRONMENTAL

**Operating Temp.:**  $0^\circ\text{C}$  to  $+40^\circ\text{C}$   
**Storage Temp.:**  $-10^\circ\text{C}$  to  $+60^\circ\text{C}$   
**Relative Humidity:** 0-80% for temperatures less than  $32^\circ\text{C}$ , decreasing linearly to 50% at  $40^\circ\text{C}$   
**Ambient Temperature:**  $25^\circ\text{C}$   
**Temp. Coefficient (per  $^\circ\text{C}$ ):**  $\pm 100\text{PPM}/^\circ\text{C}$   
**Warmup Time:** 15 minutes

### MECHANICAL

**Bezel:** 3.93" x 2.04" x .52"  
(99.8mm x 51.8mm x 13.2mm)  
**Depth:** 3.24" (82.3mm)  
**Panel Cutout:** 3.62" x 1.77" (92mm x 45mm)  
**Case Material:** PBT-ABS  
**Weight:** 9oz (255.1g)

Mode	Range (implied scale)	Typical Update Period	Minimum Input Frequency	Maximum Input Frequency	Display Resolution
0	mSec (Hz x 1000)	1.0 sec	1Hz	30KHz	0.001Hz
1	Sec (Hz)	0.5 sec	2Hz	30KHz	1Hz
2	Min (Hz x 60)	3 sec	20 Counts/Min	1.2 Million Counts/Min	1 Pulse per Minute
3	Hr (Hz x 3600)	90 sec	40 Counts/Hr	3.0 Million Counts/Hr	1 Pulse per Hour

## Wiring Diagram

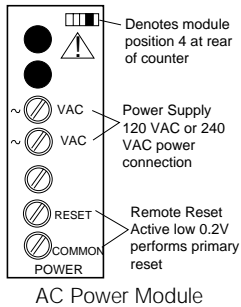

**Power Module:** The AC power module allows the S661 to be operated from standard 50/60Hz line power. The power module will be configured as 120 or 240VAC per markings on the back panel. Ensure the input rating of the supply matches your line voltage. The power supply module has provisions for a hard-wire Count Reset. This control can be a switch, relay contact or solid state device. The reset circuit is independent of the power circuit.

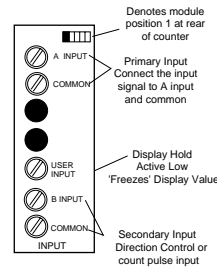

ing is based on the type of sensor that is being used. If a PNP (sinking) sensor is being used, set the input board for sinking also (switches 3 and 6 = OFF). If channel B is not used, default settings for switch positions 1 through 3 should be selected.

The Input module also provides for a User input signal. On the S661, this input serves as a display hold. While active, the rate value shown on the display is "frozen." Internal measurements and output controls continue to operate.

**Input Module:** The DIP switch SW1 is used to set up the counter to conform to the electrical characteristics of the sensor or signal being detected. Switch positions 1-3 configure channel B, while switches 4-6 configure channel A. These switches select bias (threshold voltages), low pass filter (enable/disable) and sensor type (sink or source). Refer to the sensor's documentation for related information.

**Note:** The input boards are designed so that selecting sourcing or sink-

## Programming

Menu Category	Parameter Name	Choices/Format	Description
	Pass	000 *	<b>Password Entry and Verification</b>
	Access <—	—> denied	<b>Password Fail</b> <i>Appears if incorrect password entered</i>
	ChPass	000	<b>Password Change</b> <i>Appears if correct password entered. 000 = password protection disabled. 001-099 = secures all parameters. 100-999 = enable SPs/ ResPos access in display mode.</i>
Input Setup	A Chan	UP * Down Quad r quad	<b>Chan A Mode</b> Select count mode of A channel.
	B Chan	Dir * UP Down	<b>Chan B Mode</b> Select count mode for B channel. Note: If A channel set to Quad or R quad, this item is not accessible.

\*Default Setting

## Programming (Cont'd)

Menu Category	Parameter Name	Choices/Format	Description
RATE SETUP	Mmode	Mm sec sec* Mmi n hR	<b>Rate Mode</b> Defines the pre-scaling and sampling interval for frequency computation.
	scal e	01.0000 *	<b>Scale</b> Set Display Value 2 (Rate) scaling multiplier. Values: -9.9999 to 99.9999.
	dp	000000 * 000000. 00000.0 0000.00 000.000 00.0000 0.00000	<b>DP</b> Display Value 2 (Rate) Decimal Point location. Affects appearance of Offset and any associated SP parameters.
	oFFset	000000 *	<b>Offset</b> Set Display Value 2 (Rate) scaling offset. Values: -99999 to 999999. A decimal point will appear according to the user programmed DP position.
OPUT 1 SETUP	Mmode1	Di sabl timmed Latch * bound	<b>Output 1 Mode</b> Set the mode of operation for Output 1. Can be disabled, timed, latched or boundary mode.
	SP1=Lo <—	—> SP2=hi	<b>Output 1 Bindings</b> Reminder message indicates which and how the set points are used for comparison.
	Del ay1	010.00 *	<b>Delay 1</b> Output 1 delay time. <i>Appears only if Output 1 mode set to timed.</i>
OPUT 2 SETUP	MMode2	Di sabl timmed Latch * bound	<b>Output 2 Mode</b> Set the mode of operation for Output 2. Can be disabled, timed, latched or boundary mode.
	SP3=Lo <—	—> SP4=Hi	<b>Output 2 Bindings</b> Reminder message indicates which and how the set points are used for comparison.
	Del ay2	010.00 *	<b>Delay 2</b> Output 2 delay time. <i>Appears only if Output 2 mode set to timed.</i>
SetPnt SETUP	SP1	000010 *	<b>SP1</b> Set Point #1 Low. Values: -99999 to 999999. Decimal point will appear according to the current DP setting.
	SP2	000020 *	<b>SP2</b> Set Point #1 High. Values: -99999 to 999999. Decimal point will appear according to the current DP setting.
	SP3	000030 *	<b>SP3</b> Set Point #2 Low. Values: -99999 to 999999. Decimal point will appear according to the current DP setting.
	SP4	000040 *	<b>SP4</b> Set Point #2 High. Values: -99999 to 999999. Decimal point will appear according to the current DP setting.
Reset SETUP	RstBtn	enabl e * di sabl	<b>Reset Button</b> Enable or disable front panel reset button.
	PonRst	No * Yes	<b>Power On Reset</b> Select whether count reset event will occur at power-up
End			<b>Exit Programming Menu</b>

\*Default Setting

## Excitation Output

The Excitation Module can supply 12VDC at up to 100mA for external sensors or encoders. This excitation is isolated from the counter internal logic supply.

When using sensors or encoders that do not have a signal return, or imply a signal return that is in common with the supply voltage, a common attachment that ties the excitation supply to the logic input common may be required.

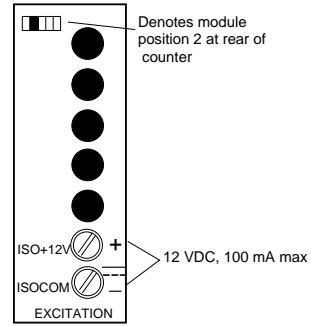

## Single and Dual Relay Modules

The Single and Dual Relay modules can activate circuit loads of up to 5 amps at 250VAC. A Form C configuration allows use of normally-open (NO) and normally-closed (NC) circuit action.

Only the output 1 channel is implemented in the single relay module.

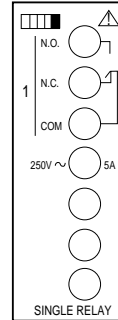

Single Relay Module

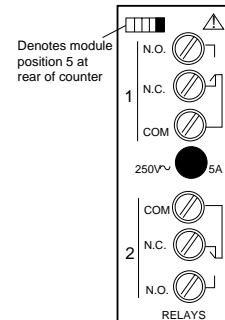

Dual Relay Module

## Application Example

A Simpson Counter is used to measure the flow rate of product pumped from a storage tank into shipping containers.

A 'Pulse Wheel' flow gauge is used to detect the flow of liquid into the pump infeed pipe.

During pumping, a bell is to sound when flow falls below a minimum of six gallons-per-minute or above 75 gallons-per-minute.

### Machine Specifications

**Flow Gauge:** 25 pulses are generated for every gallon of liquid that passes through the sensor. The output is a high speed "reed" type contact.

**Pump:** A 120VAC electric pump draws liquid from the storage tank via the flow gauge. The pump has a maximum pumping capacity of 100 gallons-per-minute with this piping arrangement. The pump runs off its own power source, but is activated by a 120VAC control signal which draws less than 0.1 amps.

### Siren:

The alarm operates from 120VAC at 0.5 amps maximum.

### Display:

Desired display of flow will be in gallons-per-minute (GPM) with one decimal place (###.# GPM).

### Process:

Problems have occurred in the past with contaminants obstructing the flow or operators not attaching the appropriate fill nozzle. Both conditions cause the actual flow to be above or below an expected amount. Detection of these conditions will minimize maintenance expenditures.

### Product Ordering Information

In the above application example, a Simpson S661 Preset Rate Counter with a 120VAC power supply, Standard Input, Signal Relay Output and no excitation is used. (catalog no. S661-1-1-0-0)

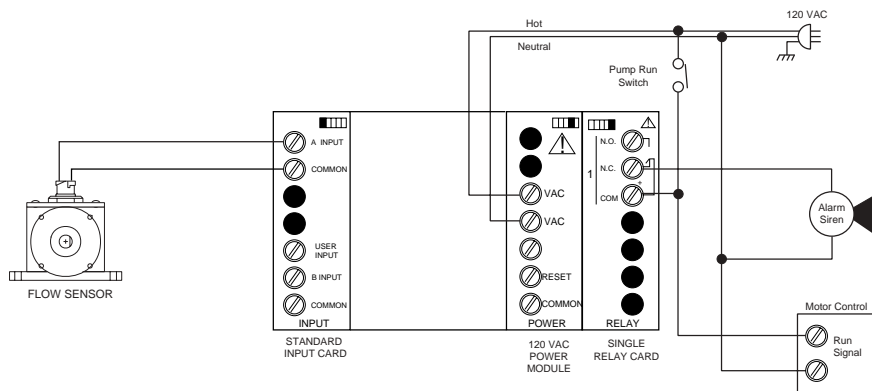

## Ordering Information

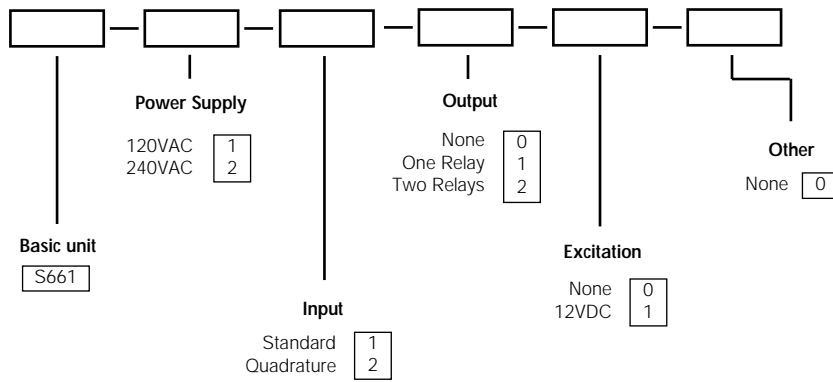

## Safety Symbols

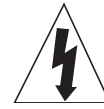

The WARNING sign denotes a hazard. It calls attention to a procedure, practice, or the like, which, if not correctly performed or adhered to, could result in personal injury.



The CAUTION sign denotes a hazard. It calls attention to an operating procedure, practice, or the like, which, if not correctly adhered to, could result in damage to or destruction of part or all of the instrument.

## Accessories



### SE Quadrature Encoder

The cube-style, dual-shaft SE Encoder is available with a choice of five different resolutions (pulses/revolution) to handle a broad range of measuring jobs. When the encoder is affixed to a chariot with measuring wheels and wired to one of the S660 series counters, cut-to-length measurement applications are assured an accurate and reliable reading.



### Flexible Shaft Couplings

The one-piece flexible coupling connects the shaft of a cube-style encoder to an ancillary equipment shaft without worry of misalignment or rotary frequency. The coupling ensures minimum windup, minimum rotary oscillation, and no hysteresis.

<u>Pulses Per Revolution</u>	<u>Catalog No.</u>	<u>Description</u>	<u>Catalog No.</u>
60	SE-060	Coupling: For connecting an encoder to a 3/8" shaft	46002
100	SE-100	Coupling package: For connecting an encoder to 1/4" or 5/16" diameter shaft*	46003
120	SE-120		
360	SE-360		
600	SE-600	*Package includes: One flexible coupling (1/2" I.D.) and three reducing inserts (1/4", 5/16", 3/8").	

## Engineer's Notes

---



---



---



---



---



---



---



---



---



---